



AIR HANDLING UNIT

PRIME Compact

TERMOVENT
Part of
MBT Climate

INTRODUCTION

We are committed to creating ideal working conditions with minimal costs and development of products that meet rigorous requirements of today's quality and energy efficiency practices. While being dedicated to principles of sustainable development, we are striving for the future development of our company.

Our core production is dedicated to manufacturing and installation of central air preparation systems - Termovent Air Handling Units (AHUs).



OVERVIEW

Production facility:
Kladovo, Serbia

Founded
1993

PART OF
MBT
Climate

HQ
Belgrade
Serbia

Widespread experience in manufacturing and designing HVAC equipment resulted in range of products created to successfully address various air conditioning, ventilation and air distribution problems. Termovent AHUs can cover various air flow rates ranging from 600 to 100,000 m³/h. The AHUs can be produced in more than 30 standardized sizes, with high levels of customization to satisfy customer requirements and project specifics.

Our AHUs are manufactured in compliance with a group of harmonized ISO standards, as well as European Union (EU) and Eurasian Customs Union (EAC) machinery directives and conform all rules regarding CE and EAC markings. Quick delivery, easy installation and simple maintenance make Termovent Air Handling Units an excellent choice in designing and implementation of air preparation and processing systems to be applied in hospitals, pharmaceutical, nanotechnology, processing,

food and automotive industry, as well as in commercial facilities and swimming pools.



CONTENT

ABOUT US	1
BEHIND THE INNOVATION	5
INTRODUCTION OF COMPACT PRIME SYSTEM	6
MAIN ADVANTAGES	7
CHOOSE YOUR COMPACT PRIME MODEL	9
ROTARY HEAT EXCHANGER	10
CONDENSATION TYPE PLATE HEAT EXCHANGER	14
ENTHALPY PLATE EXCHANGER	18
PERFORMANCE CHARACTERISTICS	21
CASE STUDY: ENERGY VAV	24
PANEL CONSTRUCTION AND	25
HOW COMPACT PRIME FUNCTIONS	35
SELECT YOUR AHU WITH CLIMATE PRIME	36
INSTALLATION, COMMISSIONING & CONNECTION	37
REFERENCES & TESTIMONIALS	39
CERTIFICATIONS, DIRECTIVES AND STANDARDS	41



BEHIND THE INNOVATION

COMPACT PRIME

DESIGNED TO FIT. BUILT TO PERFORM.

This catalogue presents COMPACT PRIME, the frameless air handling unit system developed by Tervoent. Designed with performance, efficiency, and simplicity in mind, this guide provides a complete overview of our innovative solution - from core advantages and technical specifications to component details and real-world applications.

Whether you're selecting the ideal unit for your project or exploring advanced functionalities, this catalogue will support you in making informed decisions. You'll also

find insights into our panel construction, performance features, accessories, and control options - all engineered to meet the highest industry standards.

At Tervoent, we believe that modern HVAC solutions should be compact, flexible, and future-ready. Compact Prime is our answer to that belief.

INTRODUCTION OF TERMOVENT COMPACT PRIME SYSTEM

COMPACT PRIME

DESIGNED TO FIT. BUILT TO PERFORM.

GENERAL CHARACTERISTICS

This advanced system features a frameless design that not only reduces costs but also improves energy efficiency. With a standardized selection process, it minimizes errors in component choice, while the optimized internal space ensures a compact, yet powerful, performance. Compact Prime offers a versatile and reliable solution for various applications, combining efficiency with cost-effectiveness.

APPLICATION

The application is particularly valuable in the following industries, where space efficiency, easy installation, and reliable indoor climate control are essential:

- Residential buildings
- Offices
- Restaurants
- Schools

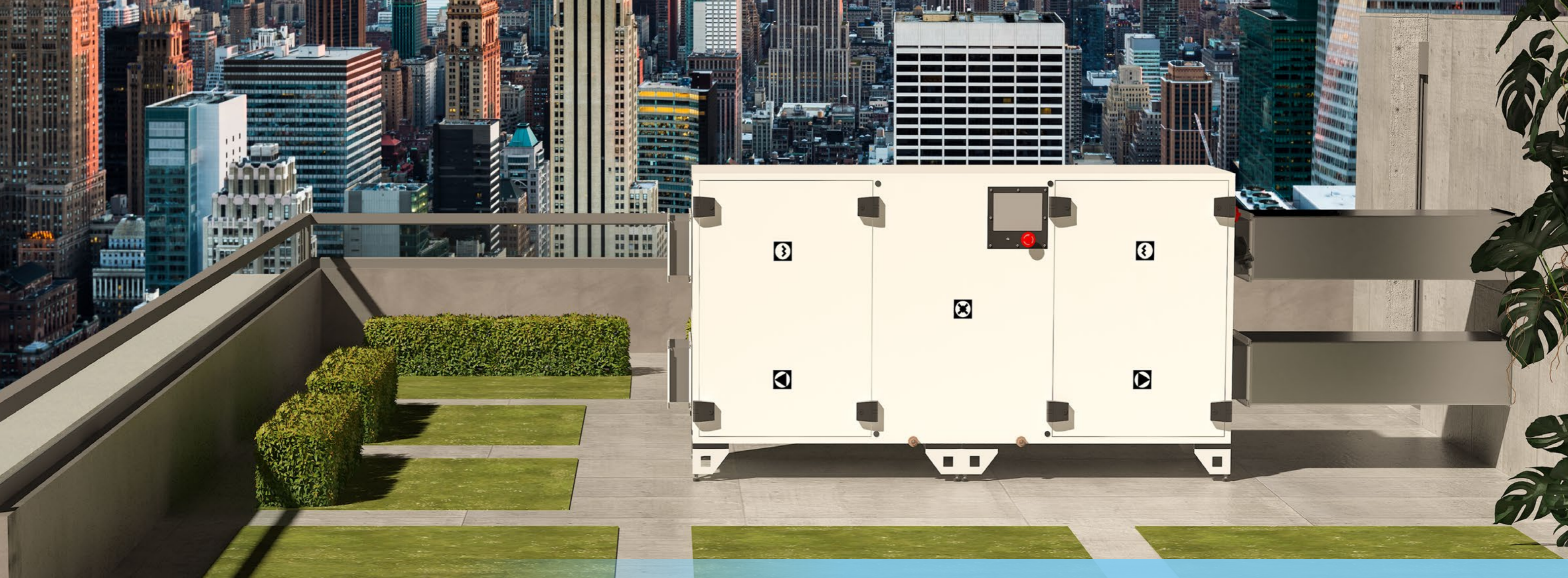

MAIN ADVANTAGES OF COMPACT PRIME

- **SCALABLE PERFORMANCE:**
Available in 5 sizes to accommodate volume flow rates up to 6,300 m³/h, ensuring optimal performance for various applications.
- **PLUG AND PLAY:**
Quick installation in just 15 minutes – plug & play solution with integrated automation. Compact design saves space, eliminating the need for control cabinets and long installation works.
- **ENERGY EFFICIENCY:**
Achieves energy recovery up to 85%/80% through rotary wheel or counterflow plate heat exchangers, verified in certified laboratories.
- **CUTTING-EDGE TECHNOLOGY:**
Incorporates the latest advancements in energy performance, fully compliant with Eco Design (ERP) standards.
- **SUPERIOR FILTRATION:**
Equipped with mechanical high-efficiency compact rigid bag filters for enhanced air quality.
- **QUIET OPERATION:**
Exceptionally low noise levels – up to 43 dB reduction on return frequencies – ensure quiet and stable operation, making it ideal for facilities with high acoustic comfort requirements.
- **ENERGY-EFFICIENT COMPONENTS:**
EC motors, reducing energy consumption by up to 20% compared to conventional AC motors.
- **USER-FRIENDLY SOFTWARE:**
Selection process under 3 minutes via a dedicated web tool designed for specifiers and HVAC engineers.
- **ADAPTABILITY:**
Ideal for both new buildings and retrofitting projects, offering flexibility and ease of integration.
- **CLOUD CONNECTIVITY:**
24/7 remote access with real-time analytics, energy tracking, and diagnostics through cloud integration.
- **COST-EFFECTIVE OPERATION:**
Combines energy-efficient components and advanced controls to reduce operating costs by up to 30%.

ROTARY HEAT EXCHANGER

HEAT RECOVERY EFFICIENCY

up to **85%**

MOISTURE TRANSFER

up to **70%**



CHOOSE YOUR **PRIME Compact MODEL**

HOW TO CHOOSE YOUR AHU

The COMPACT PRIME system offers two distinct models: **SMART** and **PREMIUM**.

SMART option includes carefully selected components that ensure stable and efficient system operation. This version is an excellent choice for those looking for a reliable solution that meets all essential requirements.

PREMIUM option, while maintaining the same high level of quality, features fans and sensors from globally renowned manufacturers known for their superior performance and durability. This option is designed for users who prefer solutions with proven components from leading industry brands.

There are **5 sizes** where you have the flexibility to choose from **three types of heat exchangers**, each designed to provide varying levels of energy efficiency and cost savings.

To further enhance durability, **COMPACT PRIME units are available for both indoor and outdoor installations**, with a protective roof designed to reduce the risk of panel corrosion. This ensures that you can customize your air handling unit to achieve optimal performance and longevity while meeting your budgetary requirements.



RECOMMENDED APPLICATIONS:

- Office buildings
- Schools
- Sports facilities

ADVANTAGES:

- High efficiency in both heat and moisture transfer
- Compact design with stable performance throughout the year
- Less sensitive to frost formation

Airflow Distribution – CompactPRIME R

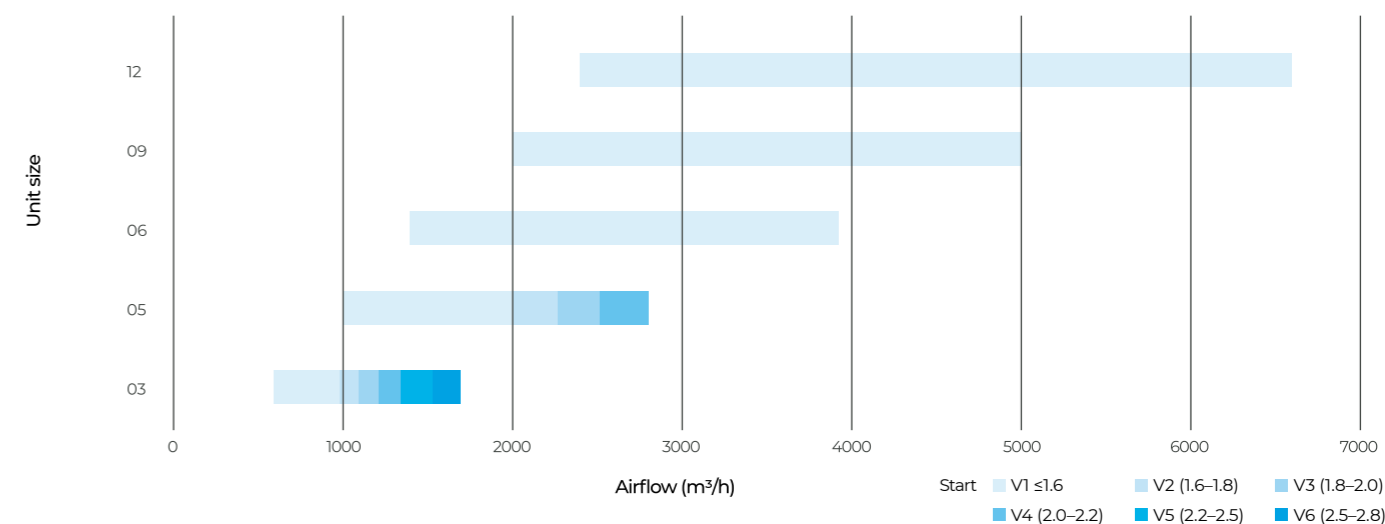

LOW SPEED: At lower speeds, the AHU operates with minimal energy consumption. However, while this setting reduces energy use, it may result in lower airflow and reduced overall efficiency in meeting the desired environmental conditions.

OPTIMAL SPEED: Operating at an optimal speed balances energy consumption with performance. This setting maximizes the AHU's

efficiency, providing adequate airflow and temperature control while minimizing energy use.

HIGH SPEED: At higher speeds, the AHU increases airflow and performance, which can be beneficial for applications requiring higher capacity. However, this setting also leads to higher energy consumption and can increase operational costs.

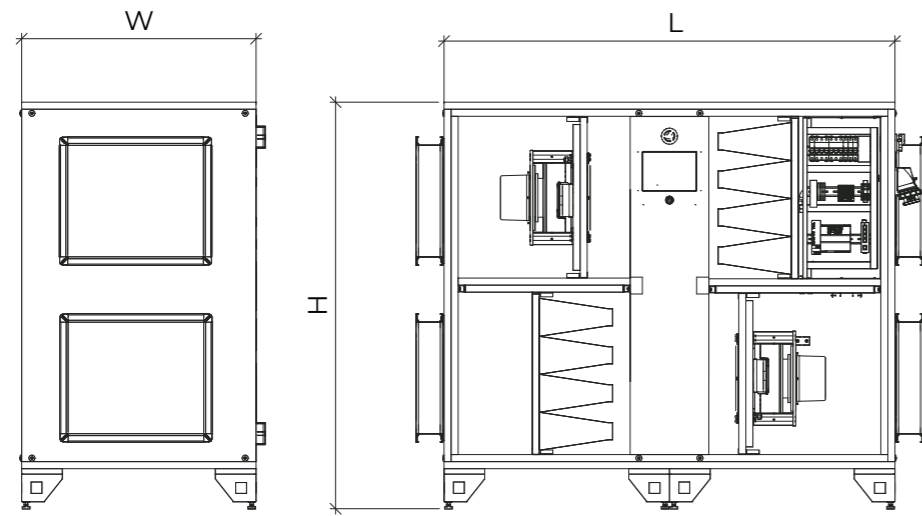

Unit type	Nominal air flow	Dimensions		
		W (mm)	H (mm)	L (mm)
R 03	1100	705	960	1800
R 05	1900	865	1355	1800
R 06	3000	1020	1355	1825
R 09	4200	1195	1355	1980
R 12	5200	1295	1355	1980

Unit type		R 03	R 05	R 06	R 09	R 12
Min	m ³ /h	600	1000	1400	2000	2400
Nom	m ³ /h	1100	1900	3000	4200	5200
Max	m ³ /h	1700	2300	3450	5000	6300

Unit type

Nominal air flow for rotary heat exchanger (R):					
	R03	R05	R06	R09	R12
m ³ /h	1100	1900	3000	4200	5200

Filtration					
Fine filter - Rigid bag filter					
Fresh / Supply air	ePM10 70% (M6); ePM1 55% (F7); ePM1 70% (F8)				
Return air	ePM10 70% (M6); ePM1 55% (F7); ePM1 70% (F8)				

Rotary heat exchanger (R):						
Material						
Aluminium						
Energy efficiency according to DIN EN 13053 ⁽¹⁾	%	78	78	77	78	77
Energy efficiency according to EN 308 ⁽¹⁾	%	80/77	80/76	79/75	79/76	79/75

Cooling coil ^(2, 4)						
Cooling capacity	kW	2.22	3.9	6.16	8.69	10.77
Water flow rate	m ³ /h	0.38	0.67	1.06	1.48	1.85
Water pressure drop	kPa	4.785	12.1	7.315	8.371	9.944
Connections	DN	20	20	25	25	32

Heating coil ^(3, 4)						
Heating capacity	kW	2.67	4.68	7.59	10.49	13.28
Water flow rate	m ³ /h	0.33	0.58	0.94	1.3	1.64
Water pressure drop	kPa	3.564	3.597	6.457	6.644	6.765
Connections	DN	20	20	20	25	25

External pressure drop*						
Fresh and supply air duct	Pa	300	300	300	300	300
Return and exhaust air duct	Pa	300	300	300	300	300

Device data						
Rotary:						
Total electrical power rating	kW	0.71	1.1	1.79	2.71	3.83
Total current consumption	A	4.6	3.2	4.8	4.6	8.6
Sound pressure level - to surroundings	dB(A)	66	62	61	63	65

Operating voltage	
1~230; 3~400 V, 50/60 Hz	

⁽¹⁾ The data is valid for the following parameters:
 Indoor conditions winter mode 20 °C/40 %
 Indoor conditions summer mode 26 °C/50 %
 Outdoor temperature and relative humidity winter mode -6.7°C/74%
 Outdoor temperature and relative humidity summer mode 34.6 °C/30 %

⁽²⁾ At supply temperature 18 °C for nominal air flow, water temperature in/out: 7/12 °C
⁽³⁾ At supply temperature 22 °C for nominal air flow, water temperature in/out: 35/28 °C
⁽⁴⁾ Inlet conditions after heat exchanger
⁽⁵⁾ For external pressure drop 250 Pa with average filter contamination
 * Max allowed pressure drop in duct system at nominal air flow

There is coil option to choose water/ethylene and propylene in some %

CONDENSATION-TYPE PLATE HEAT EXCHANGER

HEAT RECOVERY EFFICIENCY

UP TO **73-84%**

MOISTURE TRANSFER

none (condensate is drained)

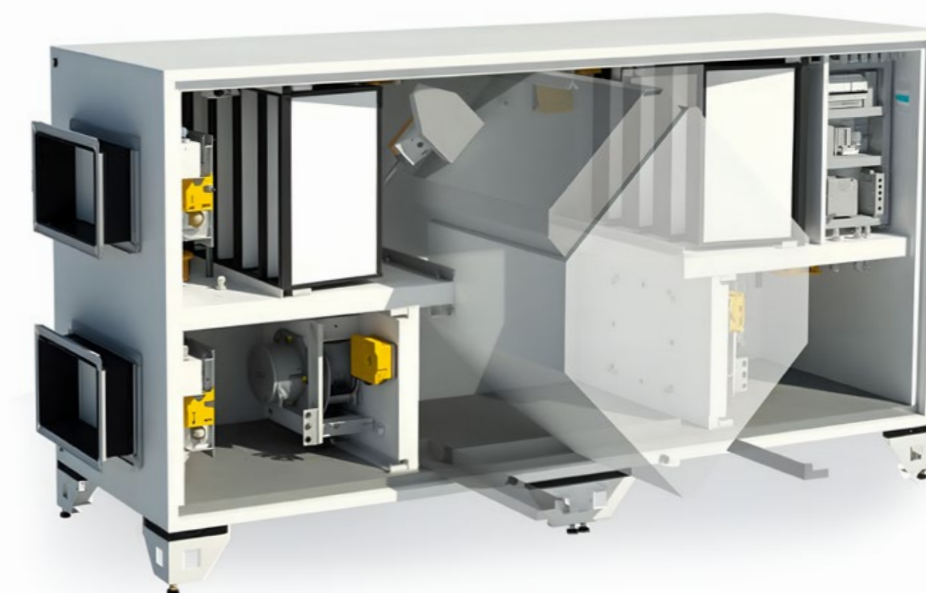

CHOOSE YOUR ^{PRIME} Compact MODEL

HOW TO CHOOSE YOUR AHU

The COMPACT PRIME system offers two distinct models: **SMART** and **PREMIUM**.

SMART option includes carefully selected components that ensure stable and efficient system operation. This version is an excellent choice for those looking for a reliable solution that meets all essential requirements.

PREMIUM option, while maintaining the same high level of quality, features fans and sensors from globally renowned manufacturers known for their superior performance and durability. This option is designed for users who prefer solutions with proven components from leading industry brands.

There are **5 sizes** where you have the flexibility to choose from **three types of heat exchangers**, each designed to provide varying levels of energy efficiency and cost savings.

To further enhance durability, **COMPACT PRIME units are available for both indoor and outdoor installations**, with a protective roof designed to reduce the risk of panel corrosion. This ensures that you can customize your air handling unit to achieve optimal performance and longevity while meeting your budgetary requirements.



RECOMMENDED APPLICATIONS:

- Residential buildings
- Small Technical and Industrial facilities
- Restaurants.
- Kitchens
- Areas requiring complete physical separation between airflows

ADVANTAGES:

- Complete separation of air streams
- Protection against contamination
- Easy cleaning and maintenance

AHU Volume Flow Rates and Sizes (Plate Condensation Type)

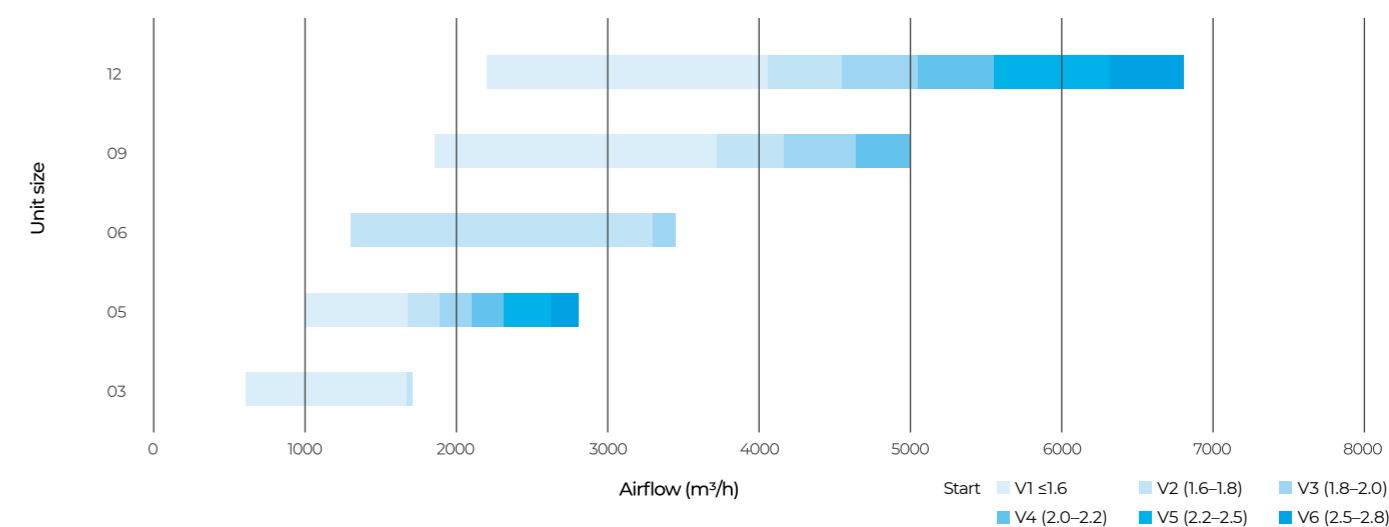

LOW SPEED: At lower speeds, the AHU operates with minimal energy consumption. However, while this setting reduces energy use, it may result in lower airflow and reduced overall efficiency in meeting the desired environmental conditions.

OPTIMAL SPEED: Operating at an optimal speed balances energy consumption with performance. This setting maximizes the AHU's

efficiency, providing adequate airflow and temperature control while minimizing energy use.

HIGH SPEED: At higher speeds, the AHU increases airflow and performance, which can be beneficial for applications requiring higher capacity. However, this setting also leads to higher energy consumption and can increase operational costs.

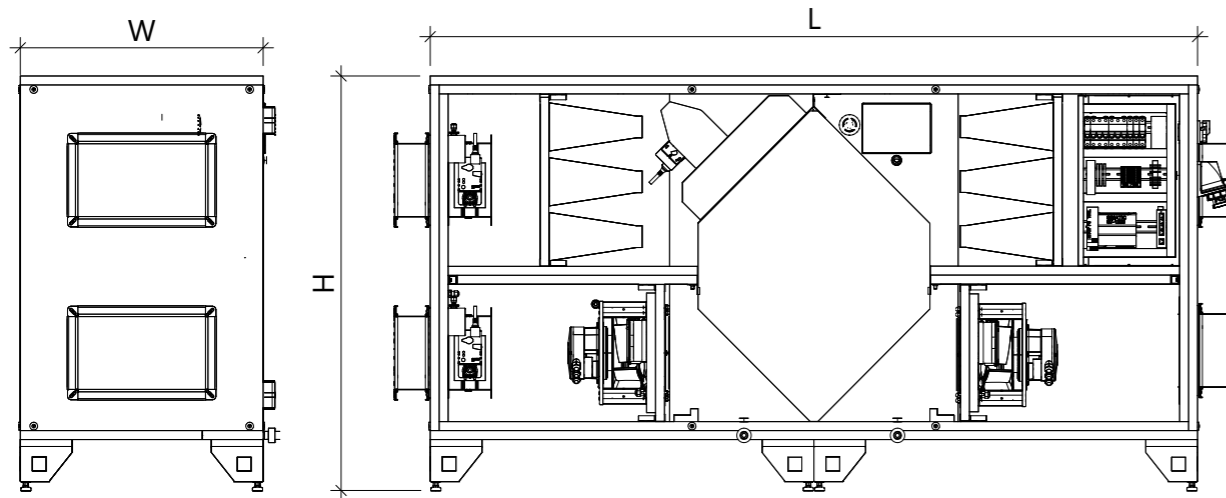

Unit type	Nominal air flow	Dimensions		
		m ³ /h	W (mm)	H (mm)
P 03	1230	705	1205	2225
P 05	1800	705	1350	2240
P 06	2400	970	1400	2390
P 09	3600	1195	1785	2480
P 12	5200	1295	1945	3000

Unit type		P 03	P 05	P 06	P 09	P 12
Min	m ³ /h	600	1000	1300	1850	2200
Nom	m ³ /h	1230	1800	2400	3600	5200
Max	m ³ /h	1700	2300	3450	5000	6300

		Unit type					
Nominal air flow for condensing heat exchanger (P):			P03	P05	P06	P09	P12
	m ³ /h		1230	1800	2400	3600	5200
Filtration		Fine filter - Rigid bag filter					
Fresh / Supply air		ePM10 70% (M6); ePM1 55% (F7); ePM1 70% (F8)					
Return air		ePM10 70% (M6); ePM1 55% (F7); ePM1 70% (F8)					
Condensing heat exchanger (P):							
Material		Aluminium					
Energy efficiency according to DIN EN 13053 ⁽¹⁾		%	76	75	75	75	75
Energy efficiency according to EN 308 ⁽¹⁾		%	77/78	75/76	75/76	76/77	77/78
Cooling coil ^(2, 4)							
Cooling capacity		kW	2.44	3.69	4.84	7.26	10.62
Water flow rate		m ³ /h	0.42	0.63	0.83	1.25	1.82
Water pressure drop		kPa	4.785	12.1	7.315	8.371	9.944
Connections		DN	20	20	32	32	40
Heating coil ^(3, 4)							
Heating capacity		kW	2.81	4.53	5.96	8.58	12.39
Water flow rate		m ³ /h	0.35	0.56	0.74	1.06	1.53
Water pressure drop		kPa	3.564	3.597	6.457	6.644	6.765
Connections		DN	20	20	20	25	25
External pressure drop*							
Fresh and supply air duct		Pa	300	300	300	300	300
Return and exhaust air duct		Pa	300	300	300	300	300
Device data							
Condensing:							
Total electrical power rating		kW	0.63	0.96	1.22	1.88	3.63
Total current consumption		A	4.6	3.2	4.8	4.6	8.6
Sound pressure level - to surroundings		dB(A)	62	61	59	61	65
Operating voltag		1~230; 3~400 V, 50/60 Hz					

⁽¹⁾ The data is valid for the following parameters:
 Indoor conditions winter mode 20 °C/40 %
 Indoor conditions summer mode 26 °C/50 %
 Outdoor temperature and relative humidity winter mode -6.7°C/74%
 Outdoor temperature and relative humidity summer mode 34.6 °C/30 %

⁽²⁾ At supply temperature 18 °C for nominal air flow, water temperature in/out: 7/12 °C
⁽³⁾ At supply temperature 22 °C for nominal air flow, water temperature in/out: 35/28 °C
⁽⁴⁾ Inlet conditions after heat exchanger
⁽⁵⁾ For external pressure drop 250 Pa with average filter contamination
 * Max allowed pressure drop in duct system at nominal air flow

There is coil option to choose water/ethylene and propylene in some %

ENTHALPY PLATE EXCHANGER

HEAT RECOVERY EFFICIENCY

73-80%

MOISTURE TRANSFER

50-65%

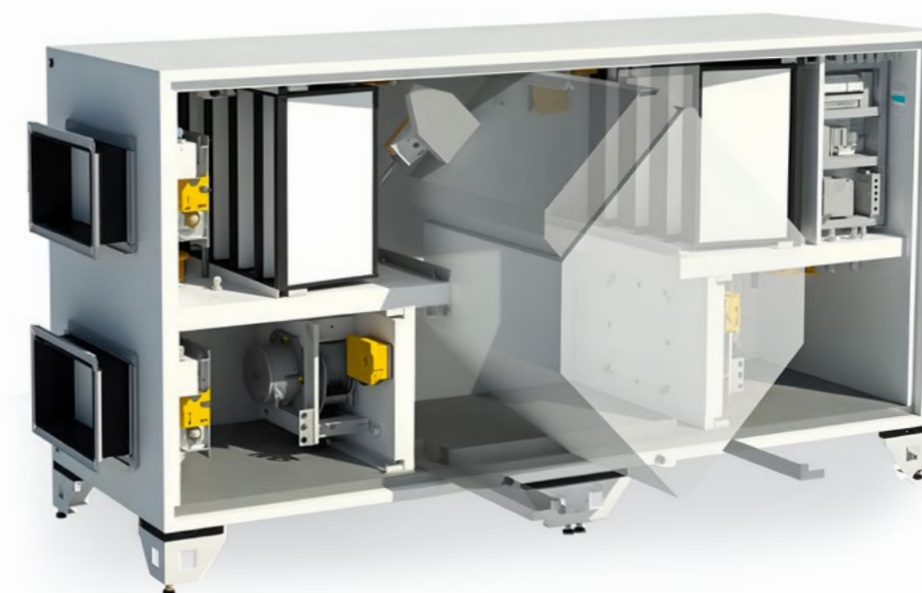

CHOOSE YOUR ^{PRIME} Compact MODEL

HOW TO CHOOSE YOUR AHU

The COMPACT PRIME system offers two distinct models: **SMART** and **PREMIUM**.

SMART option includes carefully selected components that ensure stable and efficient system operation. This version is an excellent choice for those looking for a reliable solution that meets all essential requirements.

PREMIUM option, while maintaining the same high level of quality, features fans and sensors from globally renowned manufacturers known for their superior performance and durability. This option is designed for users who prefer solutions with proven components from leading industry brands.

There are **5 sizes** where you have the flexibility to choose from **three types of heat exchangers**, each designed to provide varying levels of energy efficiency and cost savings.

To further enhance durability, **COMPACT PRIME units are available for both indoor and outdoor installations**, with a protective roof designed to reduce the risk of panel corrosion. This ensures that you can customize your air handling unit to achieve optimal performance and longevity while meeting your budgetary requirements.



RECOMMENDED APPLICATIONS:

- Residential buildings
- Hotels
- Conference rooms
- Spaces requiring comfort and indoor humidity retention
- Dry and cold climates where excessive air drying should be avoided

ADVANTAGES:

- Simultaneous transfer of heat and moisture
- Membrane barrier prevents air mixing
- Improved comfort and energy efficiency

AHU Volume Flow Rates and Sizes (Plate Enthalpy Type)

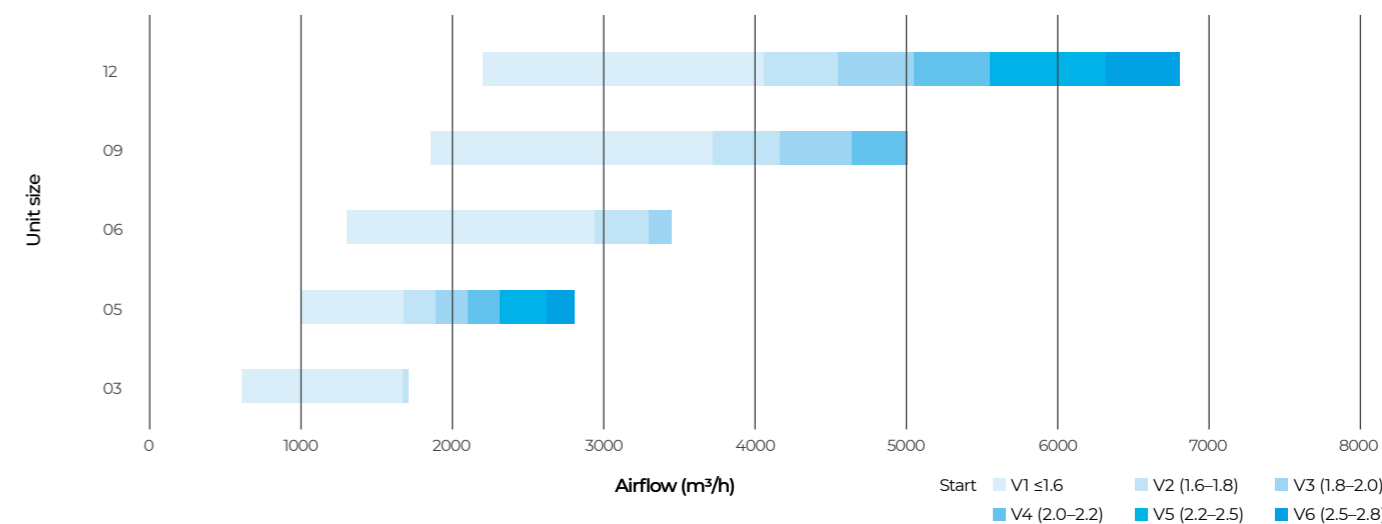

LOW SPEED: At lower speeds, the AHU operates with minimal energy consumption. However, while this setting reduces energy use, it may result in lower airflow and reduced overall efficiency in meeting the desired environmental conditions.

OPTIMAL SPEED: Operating at an optimal speed balances energy consumption with performance. This setting maximizes the AHU's

efficiency, providing adequate airflow and temperature control while minimizing energy use.

HIGH SPEED: At higher speeds, the AHU increases airflow and performance, which can be beneficial for applications requiring higher capacity. However, this setting also leads to higher energy consumption and can increase operational costs.

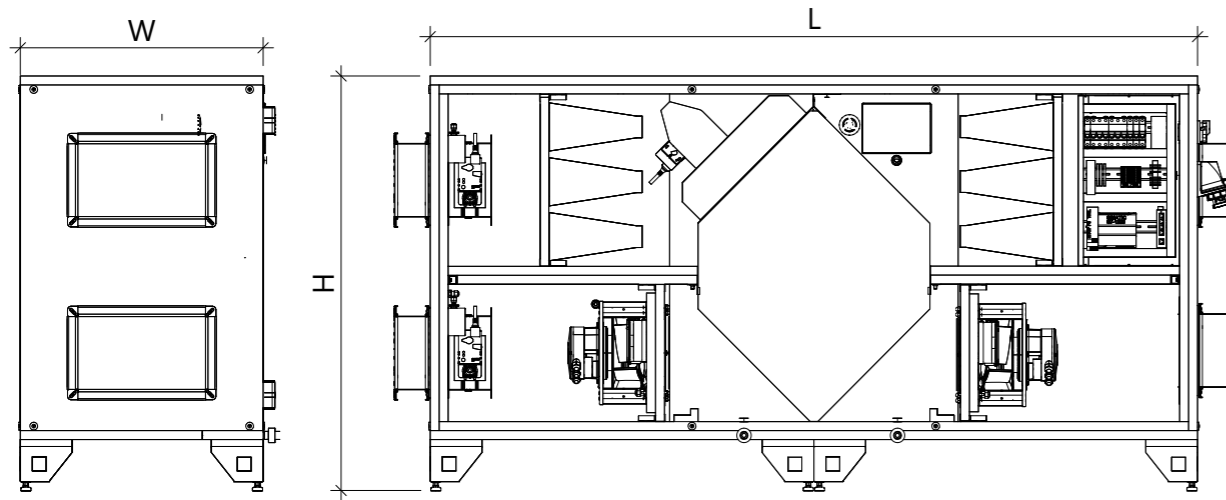

Unit type	Nominal air flow	Dimensions		
		W (mm)	H (mm)	L (mm)
E 03	900	705	1215	2225
E 05	1500	705	1500	2340
E 06	2400	970	1500	2530
E 09	3600	1195	1785	2630
E 12	5200	1295	1925	3000

Unit type		E 03	E 05	E 06	E 09	E 12
Min	m³/h	600	700	1300	1850	2200
Nom	m³/h	900	1500	2400	3600	5200
Max	m³/h	1100	2100	3200	5000	6300

Unit type

Nominal air flow for enthalpy heat exchanger (E):					
	E03	E05	E06	E09	E12
m³/h	900	1500	2400	3600	5200

Filtration					
Fine filter - Rigid bag filter					
Fresh / Supply air	ePM10 70% (M6); ePM1 55% (F7); ePM1 70% (F8)				
Return air	ePM10 70% (M6); ePM1 55% (F7); ePM1 70% (F8)				

Enthalpy heat exchanger (E):						
Material						
Polymer/PP						
Energy efficiency according to DIN EN 13053 ⁽¹⁾	%	75	75	75	75	72
Energy efficiency according to EN 308 ⁽¹⁾	%	78/79	79/80	77/78	76/77	74/75

Cooling coil ^(2,4)						
Cooling capacity	kW	2.03	3.84	5.5	8.24	12.61
Water flow rate	m³/h	0.35	0.59	0.94	1.42	2.17
Water pressure drop	kPa	4.785	12.1	7.315	8.371	9.944
Connections	DN	20	20	25	25	32

Heating coil ^(3,4)						
Heating capacity	kW	2.22	3.84	6.23	9.46	14.95
Water flow rate	m³/h	0.27	0.48	0.77	1.17	1.85
Water pressure drop	kPa	3.564	3.597	6.457	6.644	6.765
Connections	DN	20	20	20	20	25

External pressure drop*						
Fresh and supply air duct	Pa	500	800	900	700	700
Return and exhaust air duct	Pa	500	800	800	700	700

Device data						
Enthalpy:						
Total electrical power rating	kW	0.48	1.04	1.25	1.94	3.81
Total current consumption	A	4.6	3.2	4.8	4.6	8.6
Sound pressure level - to surroundings	dB(A)	45.3	44.9	48.4	51.1	59.8
Operating voltage	3~230-400 V, 50/60 Hz					

⁽¹⁾ The data is valid for the following parameters:
 Indoor conditions winter mode 20 °C/40 %
 Indoor conditions summer mode 26 °C/50 %
 Outdoor temperature and relative humidity winter mode -6.7°C/74%
 Outdoor temperature and relative humidity summer mode 34.6 °C/30 %

⁽²⁾ At supply temperature 18 °C for nominal air flow, water temperature in/out: 7/12 °C
⁽³⁾ At supply temperature 22 °C for nominal air flow, water temperature in/out: 35/28 °C
⁽⁴⁾ Inlet conditions after heat exchanger
⁽⁵⁾ For external pressure drop 250 Pa with average filter contamination
 * Max allowed pressure drop in duct system at nominal air flow

There is coil option to choose water/ethylene and propylene in some %

PERFORMANCE CHARACTERISTICS

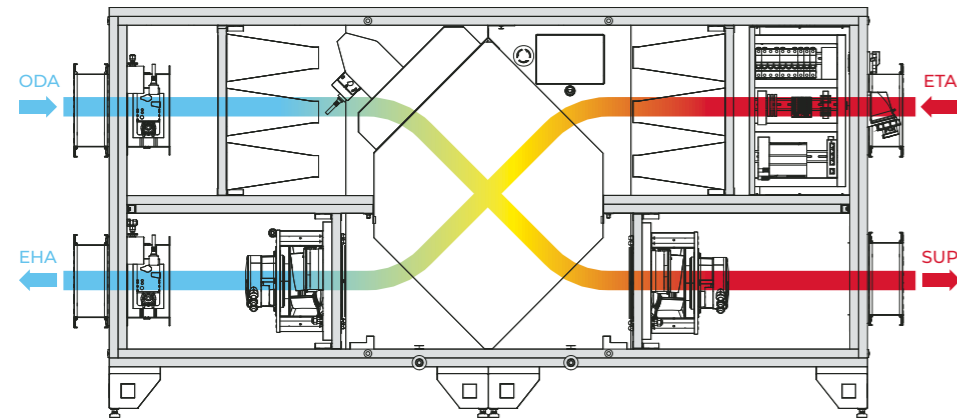

WINTER MODE

During the colder season, COMPACT PRIME units ensure a pleasant and healthy indoor environment:

- Heat recovery units use energy from exhaust air to preheat the incoming fresh outdoor air, significantly reducing the energy required for additional heating
- Additional heating elements, such as hot water coils, ensure that the supply air temperature matches the desired comfort level
- With enthalpy and rotary heat exchangers, part of the humidity is also transferred, improving comfort and reducing air dryness during winter

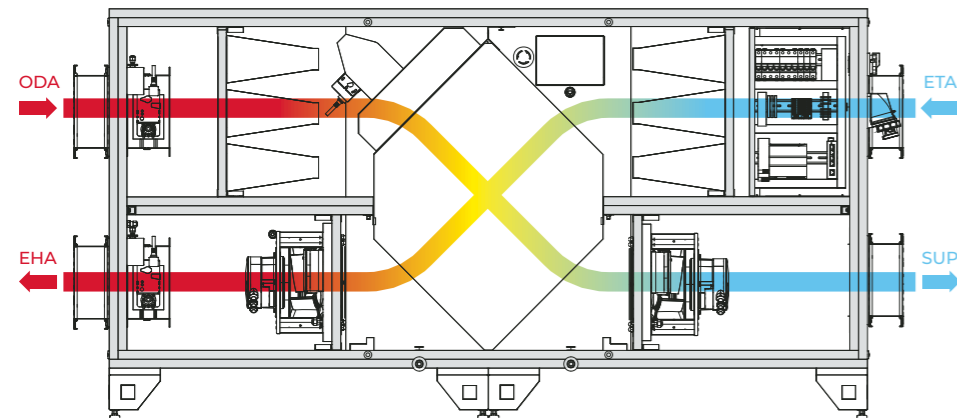

SUMMER MODE

In warm months, COMPACT PRIME provide optimal cooling and ventilation conditions:

- Heat recovery units enable the transfer of cooling energy from the exhaust air to the fresh outdoor air, reducing the load on the cooling system
- Rotary heat exchangers and enthalpy exchangers contribute to partial humidity regulation and enhanced comfort
- Chilled water coils further cool and condition the air for distribution into the space
- The free cooling function takes advantage of favorable outdoor temperatures when possible, enabling natural cooling and additional energy savings

COMFORT MODE

PURPOSE:

To ensure a constant and comfortable indoor environment by operating under fixed, predefined parameters

KEY FEATURES:

- Provides consistent temperature and air quality in all rooms
- Simple, robust, and easy to control

RECOMMENDED FOR USE WHEN:

- No VAV units are connected.
- Maximum comfort is required without compromises, with manual adjustment options (e.g., restaurants, special-purpose zones, conference rooms).
- A stable temperature and consistent air quality are needed across all spaces.

SUMMARY:

A robust mode designed for standard operation - simple, predictable, and reliable

ECO MODE

PURPOSE:

To optimize energy consumption and extend the lifespan of system components during periods when full ventilation capacity is not required.

KEY FEATURES:

- ECO mode is enabled when the AHU is connected to Energy VAV units.
- VAVs continuously monitor demand across individual zones (e.g., offices, meeting rooms) and communicate the required airflow to the AHU via Modbus.
- Fan speed is modulated through a frequency inverter, adjusting in real-time to match the total airflow demand.

ENERGY EFFICIENCY:

Lower airflow reduces pressure losses and fan workload, resulting in significant energy savings.

NOISE REDUCTION:

Lower fan speeds contribute to quieter operation, ideal for offices, nighttime conditions, and noise-sensitive environments.

EXTENDED EQUIPMENT LIFE:

Reduced operating speed minimizes mechanical stress on fans, increasing their operational lifespan.

SUMMARY:

An intelligent ventilation mode that delivers precisely the airflow. It ensures optimal energy efficiency while maintaining a high level of comfort for occupants.



ADDITIONAL ENERGY SAVER: ENERGY VAV

Energy VAV units offer an efficient solution for optimizing fan operation and reducing electrical energy consumption. By automatically adjusting airflow and fan speed according to room temperature and humidity, these units **minimize fan energy use** and noise, while **extending the fan's lifespan**.

At partial load, reduced fan speed and lower aerodynamic turbulence typically decrease sound pressure by **3-5 dB(A)**, providing a noticeably quieter operation.

Energy savings up to 50 % can be achieved on fan power at full load, and **60-80 % at partial load**, especially in regions with high electricity costs.



The diagram illustrates the significant energy savings potential with energy VAV integration:

Level	Power Non-Optimized (W/h)	Power Optimized (W/h)
3	581	391
2	383	184
1	248	72
0	189	18

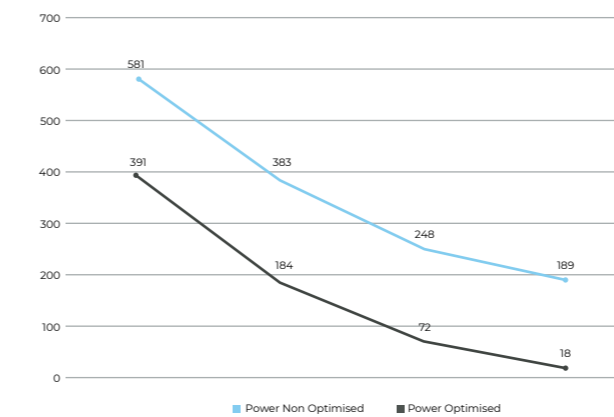

Level	Power Non-Optimized (W/h)	Power Optimized (W/h)
3	649	430
2	503	161
1	406	61
0	343	16

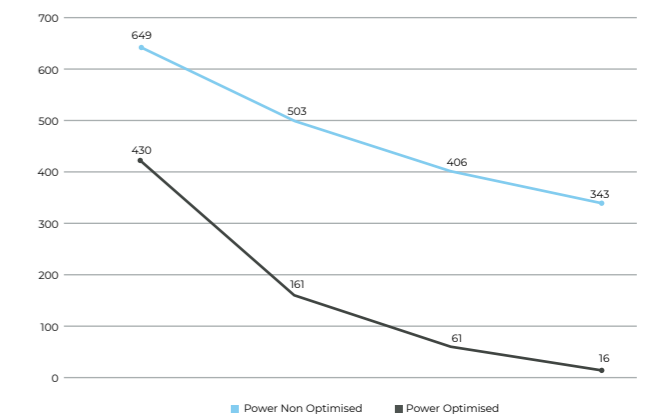

DAMPER DIAGRAMS

- Pressure-controlled system

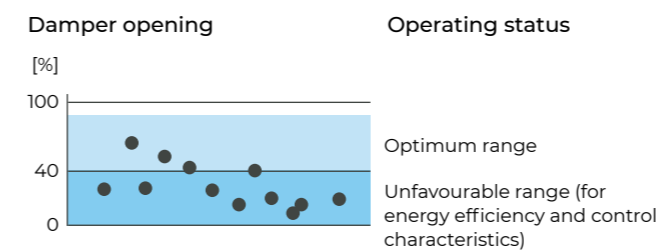

- Fan-optimised system

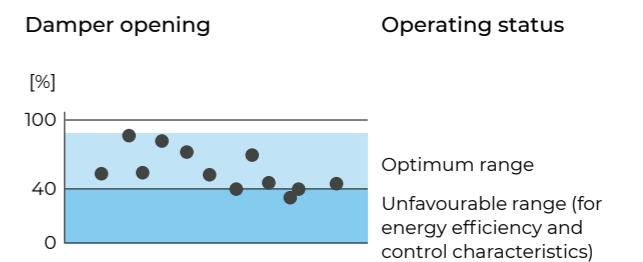

PANEL CONSTRUCTION AND CASING ELEMENTS:



PANEL

Panels are made from high-quality 0.7 mm GS DX51D+Z100MC galvanized steel sheets, offering excellent corrosion resistance without the need for additional coating. They are joined with specially developed mechanical connectors that ensure airtight, durable joints and allow easy on-site disassembly and replacement, simplifying maintenance.



SURFACES

Both sides of the panel (inner and outer) are made of the same high-quality galvanized steel, ensuring uniform resistance, ease of cleaning, and a professional, attractive finish. The smooth surfaces are ideal for areas where hygiene, aesthetics, and performance must go hand-in-hand. The surface is smooth, easy to clean, and resistant to typical environmental conditions in ventilation and air-conditioning applications.



BASE FRAME

The base of the air handling unit is formed from panels, providing the main load-bearing structure. It is dimensioned to withstand the total weight of the unit and additional dynamic forces during operation. The support foot is made of sheet steel, featuring a threaded adjustable leg and an integrated anti-vibration rubber pad.



CASING



The casing is made of self-supporting 50 mm thick panels, forming a durable and thermally efficient enclosure for the air handling unit. This construction ensures excellent mechanical strength and long-lasting reliability in operation.

INSULATION TAILORED TO YOUR NEEDS

- **Extruded Polystyrene (XPS):** Excellent thermal insulation and high mechanical stability.
- **Rock Wool:** An optional solution offering added fire resistance and superior acoustic insulation.

ENGINEERED FOR AIRTIGHT INTEGRITY

Panels are connected using specially designed joining elements that ensure a strong, stable, and airtight construction, verified through mechanical strength and leak-tightness tests.

EASY MAINTENANCE

The panels are easily removable, providing quick and convenient access to internal components - perfect for efficient servicing and system inspections.

SMART ACCESS WITH HYGIENIC ASSURANCE

Access panels are equipped with combination hinge-handle elements, without impact mechanisms, enabling safe, reliable, and easy operation.

The entire system is designed in compliance with VDI 6022 hygiene standards, making it suitable for use in hygiene-sensitive environments such as hospitals, laboratories, and the food industry.

FAN

The COMPACT PRIME AHU is equipped with an EC fan, which features integrated electronics for precise speed control. This built-in control eliminates the need for an external variable frequency drive (VFD), resulting in a more compact, energy-efficient, and reliable solution.

KEY FEATURES:

- Energy efficiency – Fan speed automatically adapts to actual demand, significantly reducing energy consumption.
- Reduced mechanical wear – Smooth start and stop functions minimize mechanical stress and extend component life.
- Quieter operation – Optimized fan control lowers noise levels during operation.
- Modbus communication – Enables remote monitoring, diagnostics, and control via the Simatic S7-1200 controller.

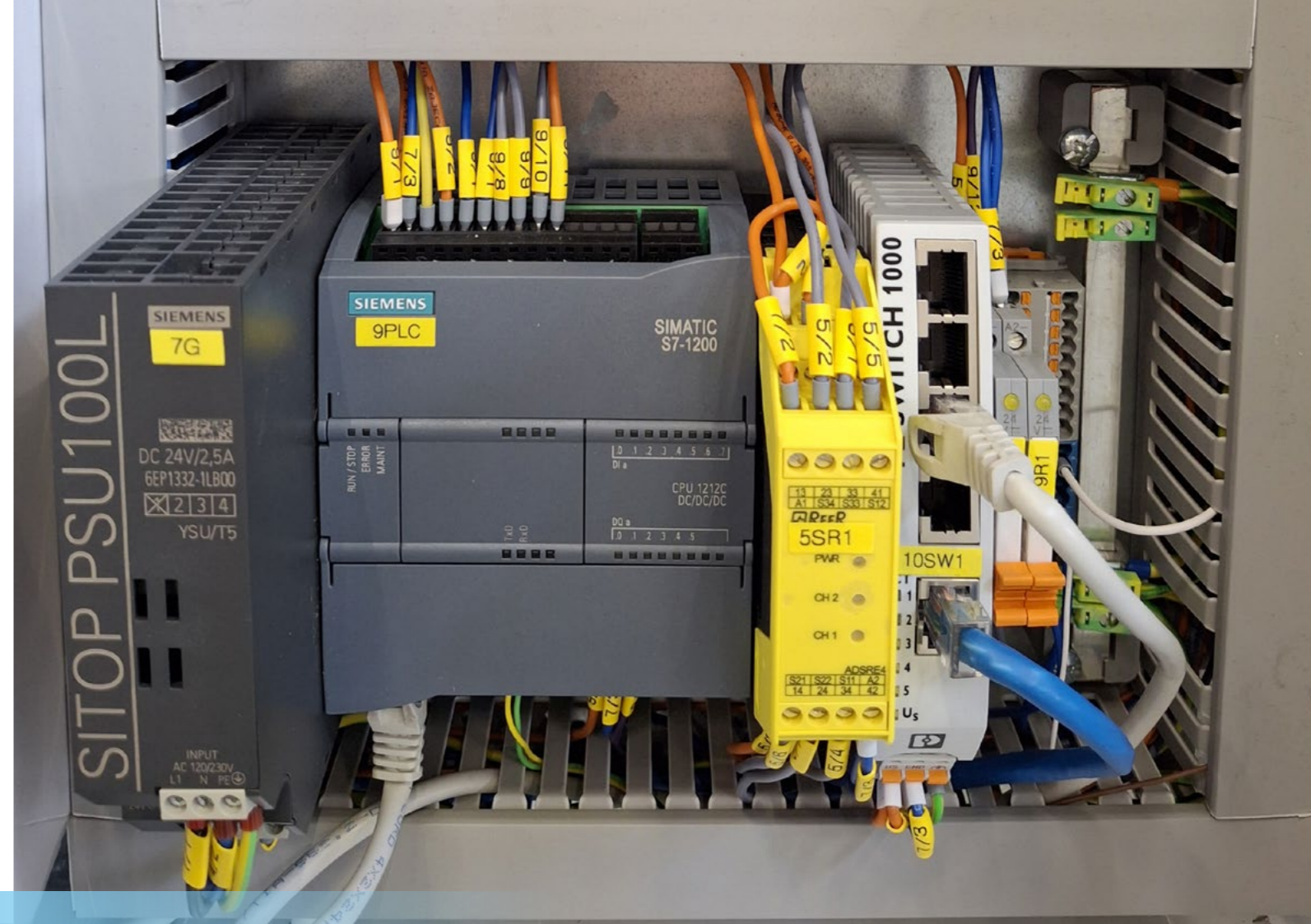

ELECTRICAL CABINET

- Electrical cabinet fully integrated into the AHU housing
- No need for additional space or external cable ducts
- Siemens S7-1200 controller with Modbus RTU communication
- Faster installation, increased reliability, and easy maintenance



HEAT RECOVERY

Efficient heat recovery systems enabling energy transfer between exhaust and supply air streams.

KEY FEATURES:

- Heat recovery rate up to 85%
- Significantly reduces energy consumption while maintaining desired indoor temperature
- Bypass function allows the heat exchanger to be bypassed under specific conditions (e.g., during mild or extreme outdoor temperatures)
- Available in Plate, Enthalpic, or Rotary configurations to meet various performance and humidity control requirements

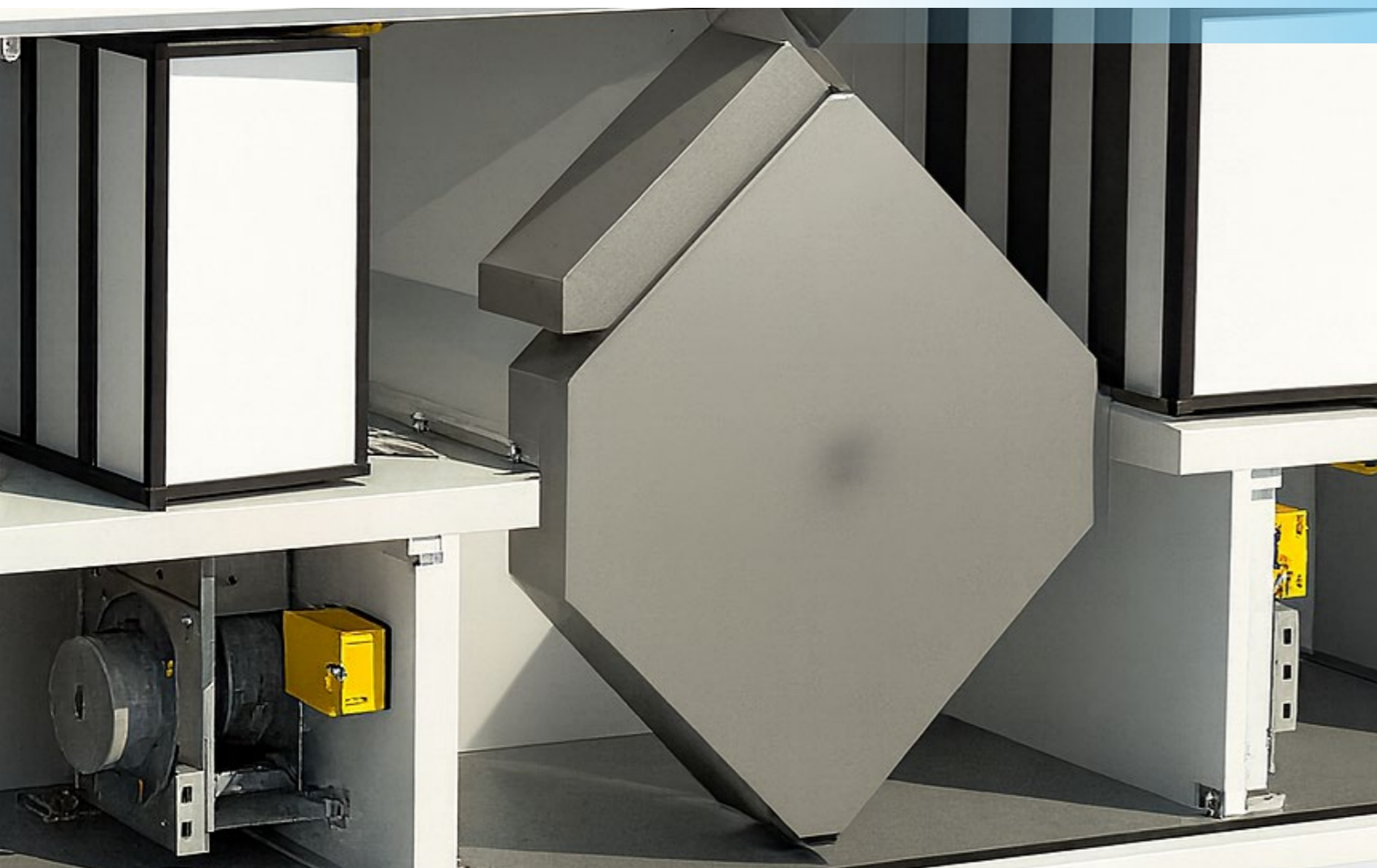

DAMPERS

Air dampers control airflow in the AHU, regulating fresh, return, exhaust, and supply air. Each damper has an electric actuator with Modbus RTU communication, allowing digital interaction with the central controller.

KEY FEATURES:

- Automated position control (open, closed, percentage) via Modbus
- Two-way communication with the Simatic S7-1200 PLC for position feedback and fault detection
- High precision for improved energy efficiency and comfort
- Status detection for malfunctions, errors, and power loss



CONTROL PANEL

KEY FEATURES:

- Central interface of the AHU system
- Real-time graphical overview of key components
- Displays parameters: temperature, humidity, pressure, fan speed, and damper positions
- Status indicators for each active system element
- Quick system status check and diagnostics
- Access to alarms, settings, and operation history via bottom menu

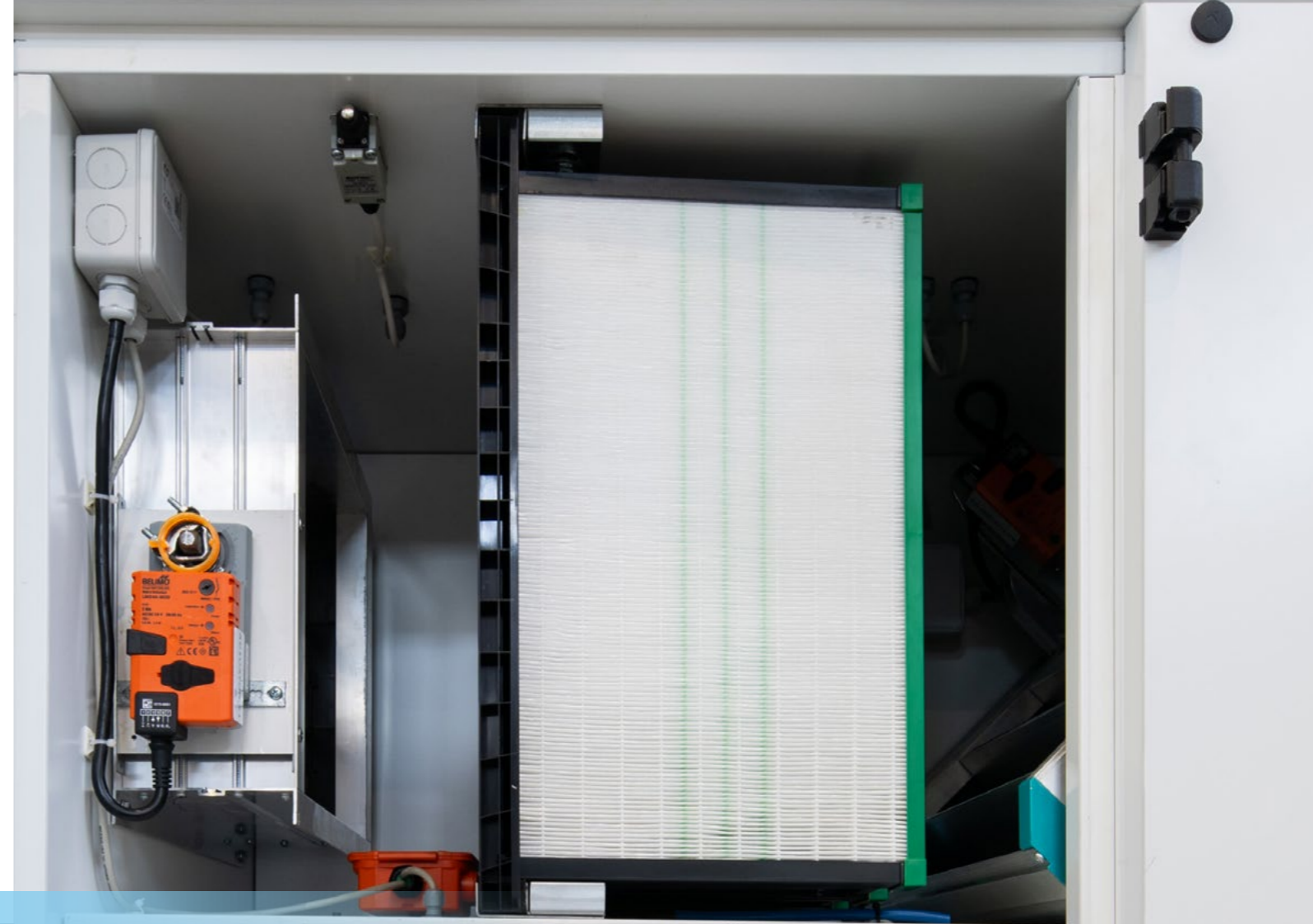

RIGID BAG FILTER

KEY FEATURES:

- Specialized for efficient air filtration in air handling unit
- High efficiency and long-lasting performance
- Retains fine dust particles and contaminants
- Resistant to wear and high temperatures
- Eurovent certified for verified performance and quality
- Classified according to the EN ISO 16890 standard



OPTIONAL FUNCTIONAL MODULES

HEATING COIL

is a key component used for heating air in ventilation and air conditioning systems, where hot water acts as the heat transfer medium. It is typically installed in the airflow path within AHU's to efficiently regulate the temperature.

KEY FEATURES:

- Material: Copper tubes and aluminum fins for optimal heat transfer
- Water from the central heating system (low-temperature, up to 80°C)
- Connected to a three-way valve with Modbus or 0-10V control to regulate water flow based on set temperature
- Stable and even heating without direct electric elements
- Economical operation with central heating systems
- Long lifespan and easy maintenance
- Ideal for: Energy-efficient buildings and systems utilizing renewable energy sources like heat pumps or biomass boilers.

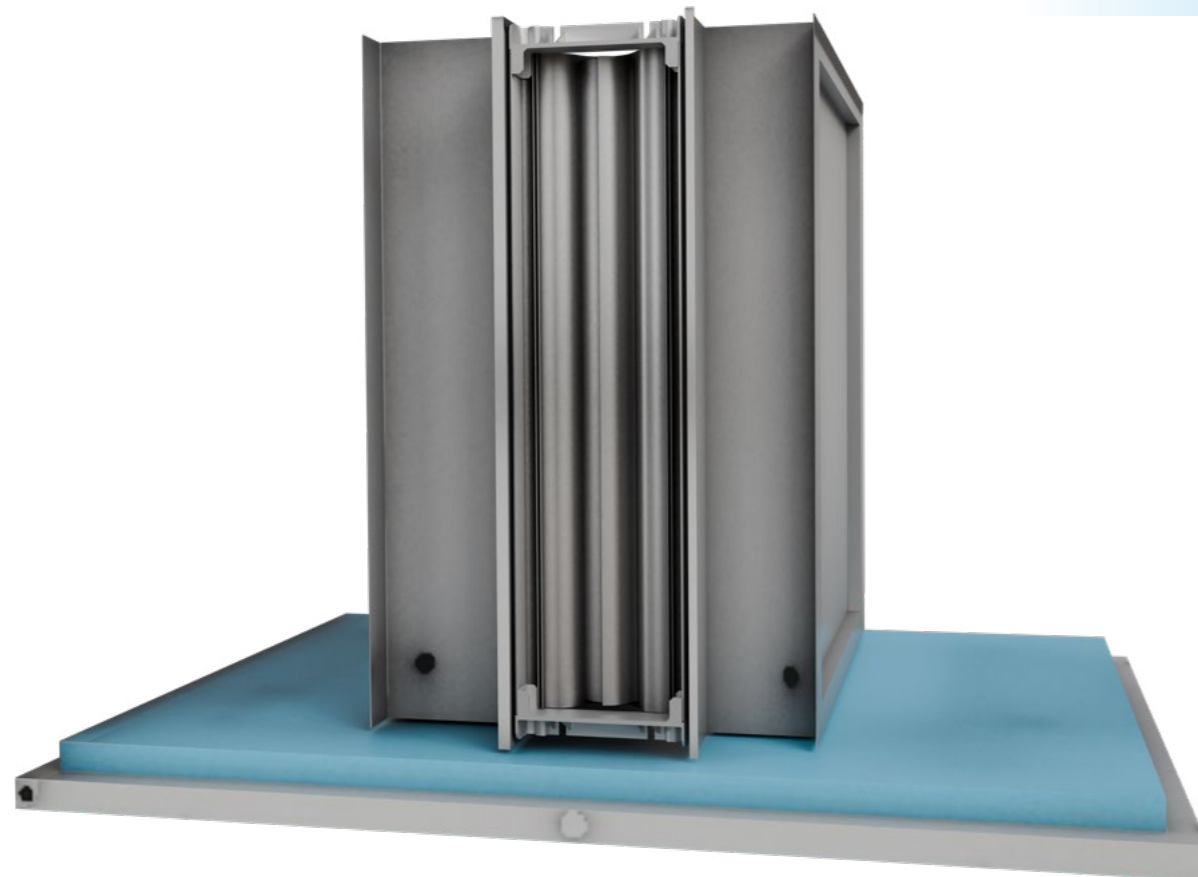
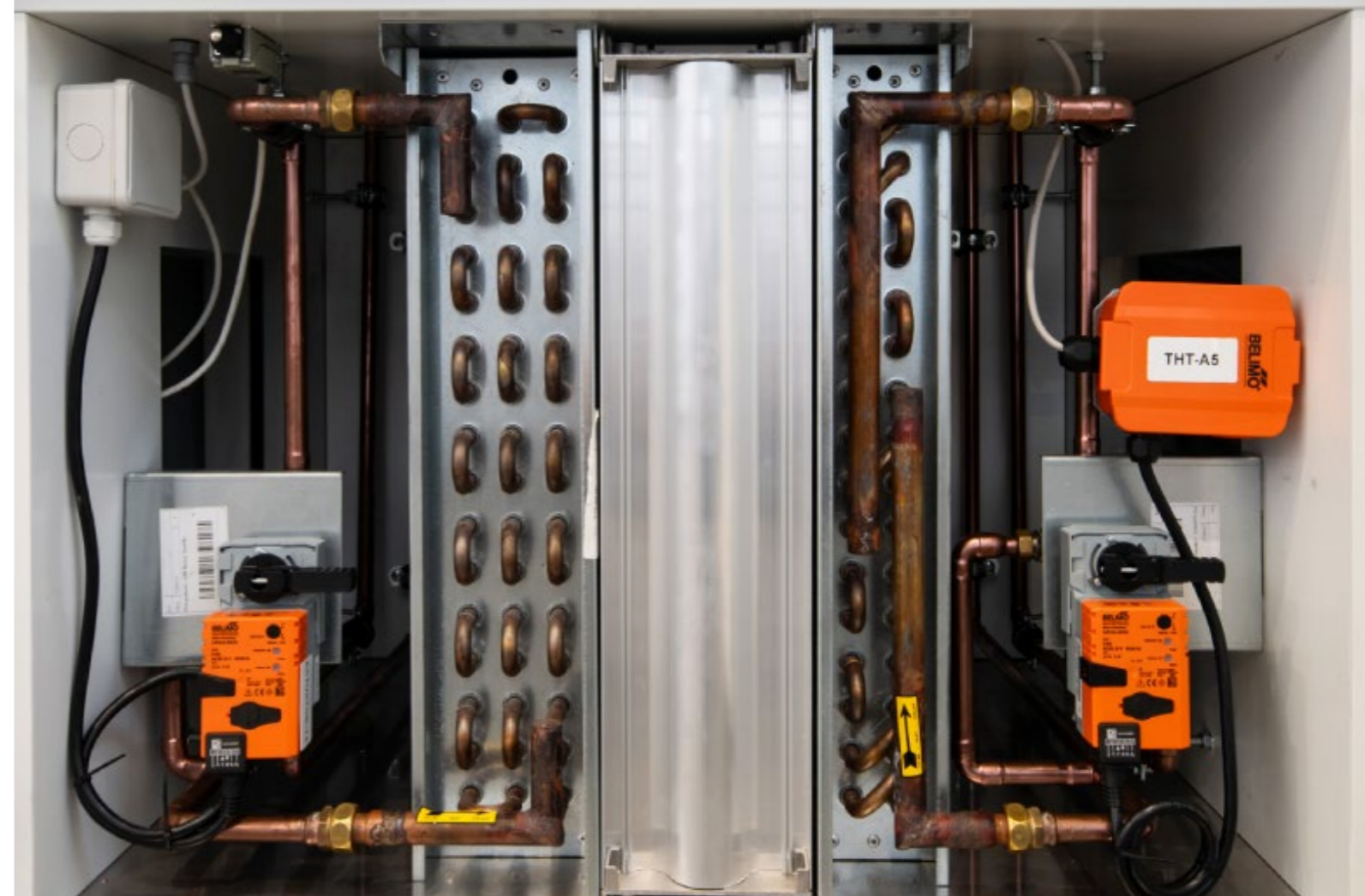

COOLING COIL

KEY FEATURES:

In the air handling unit is responsible for cooling the air passing through the system, ensuring temperature regulation in the conditioned space

- Material: Copper tubes and aluminum fins for optimal heat transfer
- Connected to a three-way valve with Modbus or 0-10V control for regulating water flow based on set temperature
- High heat transfer efficiency due to dense aluminum fins
- Precise outlet temperature control with TH sensors before and after the water coil cooling
- Frost protection with temperature safety sensors
- Integrated condensate drainage channel in the AHU panel
- Maintains a constant internal temperature, even in summer conditions

HOW CLIMATE PRIME FUNCTIONS

CHOOSE YOUR PACKAGE:

Select between the Smart and Premium packages in our user-friendly software. Each package is designed to meet various needs while maintaining a high level of efficiency.

STANDARDIZED SELECTION:

The system is designed to be as standardized as possible, minimizing the risk of selection errors and ensuring a seamless integration into your application.

CUSTOMIZE EQUIPMENT:

Within your chosen package, select from three types of heat exchangers to match your specific requirements. You can also choose to add a cooler or heater for enhanced flexibility

CONCLUSION:

If humidity control is not required in AHU, plate condensing would be the best solution. If humidity regulation is still required, the investor should decide whether to invest in enthalpy or rotary heat exchanger.



SELECT YOUR COMPACT PRIME AHU WITH CLIMATE PRIME

Climate Prime is an intuitive and user-friendly software tool designed to help you select the most suitable air handling unit for your specific project needs. Whether you're preparing a quick offer or working on a detailed technical design, Climate Prime ensures rapid product selection tailored to specific project conditions and provides you with all the technical information you need.

KEY FEATURES:

• User-Friendly Interface

The configuration process is simple and streamlined. After entering your technical requirements and project data, you can instantly download a detailed technical sheet (PDF) including performance curves, selected components, and more.

• Advanced Cost-Optimized Calculations

Our powerful calculation engine selects components in the most efficient and economical way – helping clients reduce equipment costs right from the start. The software also supports Life Cycle Cost (LCC) analysis, assisting in long-term investment planning.

• Comprehensive Technical Output

Climate Prime provides complete documentation and data, including:

- Product dimensions
- Performance and efficiency data

- Life Cycle Cost analysis
- Noise levels
- Product documentation
- Full compatibility with Revit
- Certificates
- The technical drawing, precisely scaled, can be exported to BIM programs as DXF or DWG files for seamless integration into project planning
- **Direct Sales Contact**
Once your selection is complete, you can contact our sales team directly through the platform to finalize pricing, customization, delivery terms, and any additional services.
- **Ready for Your Projects**
From the initial selection to final delivery, Climate Prime saves time, enhances accuracy, and improves collaboration between engineers, sales professionals, and manufacturers.

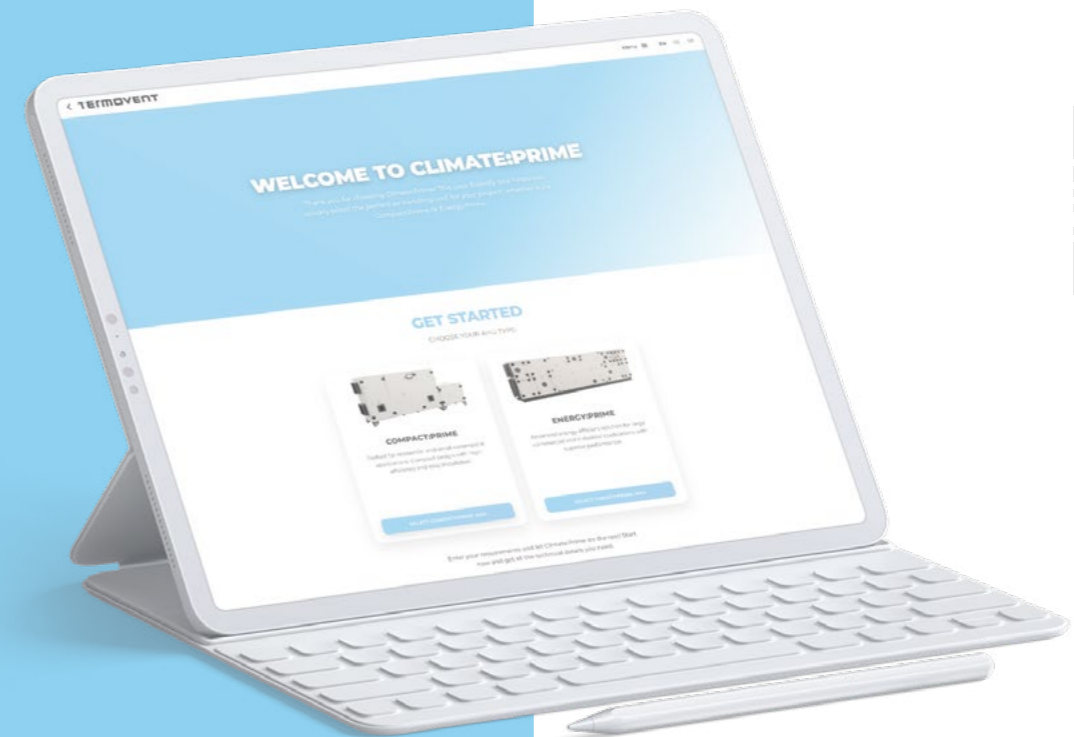

Go to Climate Prime Selection Tool

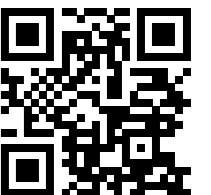

INSTALLATION, COMMISSIONING & CONNECTION

INSTALLATION

- Our COMPACT PRIME AHU units are designed for quick and efficient installation thanks to the following features:
- Fast and easy setup
- True plug and play systems – minimal effort and time required on site
- Simple connection of ventilation ducts – flexible connectors ensure quick attachment
- Seamless integration into existing ductwork

POWER SUPPLY CONNECTION

- Depending on the unit's capacity, power is supplied using either single-phase or three-phase electricity via a standard industrial connector.
- This straightforward approach ensures a safe and reliable electrical connection without complex wiring.

COMMISSIONING

- Once the unit is physically connected and powered, the system is activated by simply turning the main switch to the ON position. The entire control system is fully integrated into the unit itself — no separate electrical cabinet is required.
- An intuitive user interface with a display guides the operator through the startup process. With the press of the Start button, the unit begins operation.



DESIGNED FOR EASY ACCESS

- COMPACT PRIME air handling units are built for quick, safe and effortless servicing:
- Sliding fan assemblies with quick connectors allow tool-free removal in minutes.
- Filters are easily replaceable, while all internal parts remain fully accessible for inspection and cleaning.
- Service doors open both ways or can be completely removed for maximum access.
- Smooth surfaces and rounded corners prevent dust build-up and simplify hygiene maintenance.

With standardized components and plug-and-play connections, every service task is faster, safer, and more reliable.

REMOTE CONTROL & ASSISTANCE

- Our advanced cloud-based technology enables seamless remote monitoring and adjustment of system operating parameters via a mobile app or computer. In addition, our service team can analyze system data in real time, providing technical support and performing remote diagnostics to ensure optimal performance and minimize downtime.

REFERENCE PROJECT

COMPACT PRIME IN ACTION

Energy-efficient, intelligent, and future-proof ventilation

FIRST PROJECTS – FIRST RESULTS.

Although COMPACT PRIME has only recently been introduced to the market, it is already delivering measurable benefits. Through our distributor in Switzerland, Prolux, one of the first units was supplied to Gisler AG. This early reference demonstrates how COMPACT PRIME combines energy efficiency, intelligent control, and simplified commissioning in a future-proof solution.

DISTRIBUTOR STATEMENT – PROLUX

“With the COMPACT PRIME, we are setting new standards in central ventilation: energy-efficient, intelligently controlled, and easy to commission. In particular, the fan optimisation control with integrated commissioning assistant makes the system a future-proof solution for anyone who values consistently high air quality and sustainable operation. The fan optimisation control system, including our VAV solutions, can reduce annual operating costs by over 50%. This means that we are not only actively contributing to reducing CO₂ emissions and optimising energy consumption in buildings, but also offering maximum comfort and operational reliability at reduced operating costs.”

Vaios Doukas, Head of Business Unit Ventilation at Prolux

CUSTOMER FEEDBACK – GISLER AG

“The COMPACT PRIME reliably met all technical requirements.

Our first impression of quality, based on images, was later confirmed during the live inspection. Another major advantage was the option of using Fan Optimising together with residential ventilation boxes, which enabled us to implement a complete and well-designed solution from a single source.



Vaios Doukas
Head of Business Unit Ventilation at Prolux

The cooperation with Prolux was based on trust, supported by attractive commercial terms – a strong foundation for this decision.”

Genc Zumeri, Owner Gisler AG



KEY HIGHLIGHTS :

- **Fan Energy Efficiency**
Over 50% annual operating cost reduction
- **Advanced Control**
Integrated commissioning assistant
- **Sustainability**
Reduced CO₂ emissions
- **Comfort & Reliability**
High indoor air quality



QUALITY MANAGEMENT SYSTEM

CERTIFICATES AS THE GUARANTEE OF QUALITY

Termovent is fully committed to meeting the customer's requirements in terms of quality, environmental protection and safety. The set high quality standards are the cornerstone of our operations. In order to achieve the goals we set at all times, our employees are involved in the processes

of continuous improvement and optimization of our products and services. The success of this approach is confirmed by numerous certificates held by Termovent, which guarantee the highest standards to our customer.



CE MARKING FOR TERMOVENT AHUs

Termovent Air handling Units hold CE Marking of Conformity to Machinery Directive 2006/42/EC Annex II, Point A.

In addition, Termovent AHUs are designed and produced according to set of harmonized standards:

EN ISO 12100:2010

Safety of machinery – General principles for design – Risk assessment and risk reduction,

EN 60204-1:2018

Safety of machinery – Electrical equipment of machines – Part 1: General requirements

EN ISO 13849-1:2023

Safety of machinery – Safety – related parts of control systems Part 1: General principles for design

EN ISO 13850:2015

Safety of machinery - Emergency stop function-Principles for design

EN ISO 13854:2019

Safety of machinery – Minimum gaps to avoid crushing of parts of the human body

EN ISO 13857:2019

Safety of machinery – Safety distances to prevent hazard zones being reached by upper and lower limbs

EN ISO 14118:2018

Safety of machinery – Prevention of unexpected start-up

EN ISO 14120:2015

Safety of machinery - Guards



EUROVENT CERTITA CERTIFICATION

Eurovent Certita Certification has certified that Termovent Air Handling Units, Range Prime, and Software for calculation of performances CLIMATE PRIME, Trade name TERMOVENT, have been assessed according to requirements of the following standard: OM-5-2017



ISO 13485:2016

ISO 13485:2016 Certification body SIQ confirmed that Termovent introduced Quality Management System in accordance with ISO 13485:2016 in the field of manufacturing, design and installation of Termovent panels for the construction of clean rooms.



ISO 9001: 2015

ISO 9001: 2015 Certification body TUV SUD Management Service GmbH confirmed that Termovent introduced Quality Management System in accordance with ISO 9001:2015 standard in the field of manufacturing, installation and sales of equipment for air conditioning, heating and cooling.



ISO 14001:2015

ISO 9001: 2015 Certification body TUV SUD Management Service GmbH confirmed that Termovent introduced Quality Management System in accordance with ISO 9001:2015 standard in the field of manufacturing, installation and sales of equipment for air conditioning, heating and cooling.



ISO 45001:2018

OHSAS 18001:2007 Certification body TUV SUD Management Service GmbH confirmed that Termovent introduced Health and Safety Management System in accordance with OHSAS 18001:2007 in the field of manufacturing, installation and automation of air conditioning, heating and cooling equipment and systems.



SCC*:2011

Termovent is SCC*2011 certified by Quality Austria – meeting the highest standards of safety, health, and environmental protection.

